



Twin Screw Pump
WANGEN Twin

A
hygienic
class
of its own:

The new
generation
of the
WANGEN
Twin.



The newest WANGEN Twin generation

Form and technology in perfection

Highest level of service friendliness

- Spindle change without re-synchronisation of the spindle shafts, enabled by WANGEN PUMPEN's **fast-X-change®** technology.
- Seal change simple and fast as a result of **cartridge construction** design.
- Alignment of the coupling by a self-centring flange housing (lantern optionally available). As a result, no re-alignment of the coupling is needed, e.g. after service activities.



Large pressure range

16 - 25 bar operating pressure (according to pump size and implementation).

Extended application possibilities

Thanks to higher differential pressure and a higher flow rate through extended spindle selection (gradient).

Gentle conveying and cleaning CIP in one pump

due to optimised and technically-refined flow characteristic behaviour.

Maximum connection flexibility

through numerous nozzle variants.

Easy handling

Handles on the housing for attachment, e.g. of carrier loops or belts.

Long service life

among other things by further developed shafts.

Further highlights

- Position-independent installation of the pump possible
- 100 % backwards-compatible to the preceding WANGEN Twin generation.
- Bearing housing available in stainless steel and grey cast iron (galvanised and high-quality coated)
- Pump available with or without direct flange mounting on the drive.
- Extended, flexible drive selection.



Pump size	Maximum free ball passage (mm)	Max. flowrate (m ³ /h) at viscosity 1 mPa·s	Maximum peak pressure (bar)
Twin 70	20	25 (at 4000 min ⁻¹)	30
Twin 104	25	60 (at 3600 min ⁻¹)	30
Twin 130	30	100 (at 3000 min ⁻¹)	25
NEW Twin 180	40	200 (at 2600 min ⁻¹)	20

Conveyed media (examples)

Food and Beverages:

- Drinks: Direct juice, concentrate, mash, pulp, yeast.
- Dairy products: Yoghurt, curd, cheese, pudding, butter.
- Sauces: Ketchup, mayonnaise, mustard, soup, salad sauces.
- Confectionery: Chocolate, fondant, liquid sugar, rework, sugar, dough.
- Fruits: Strawberries, blueberries, cherries.
- Meat-based: Minced meat, sausage meat, pet food.

Cosmetics:

- Care products: Cream, ointment, lotion.
- Cleaning products: Soap, shampoo, body wash.

Chemical products:

- Coatings: paints, lacquers.
- Connection products: Adhesive, glue, binding agent.
- Base materials: Suspensions, solutions, additives.



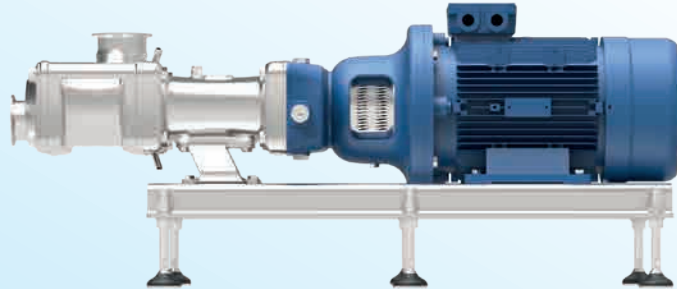

WANGEN Twin 104
with stainless steel housing
on baseplate with adjustable feet

Technical highlights:

- Flowrate: up to 200 m³/h
- Viscosity: up to 1.000.000 mPa·s
- Temperature: up to +130 °C

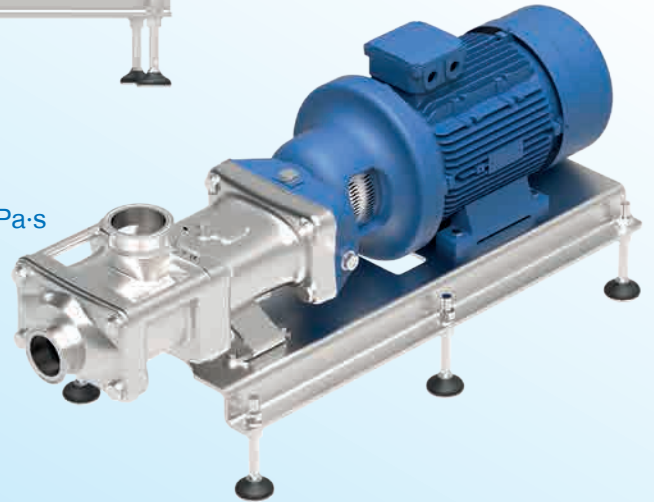

Tested quality

WANGEN PUMPEN Quality management is certified to ISO 9001:2008.



Certified sustainability

The WANGEN PUMPEN environmental management is certified according to ISO 14001:2004.



Your contact:



Product-video

Pumpenfabrik Wangen GmbH

Simoniusstrasse 17
88239 Wangen im Allg.
Germany
www.wangen.com

Technical consultation: +49 7522 997-0
Service hotline: +49 7522 997-997
Spare parts: +49 7522 997-896